

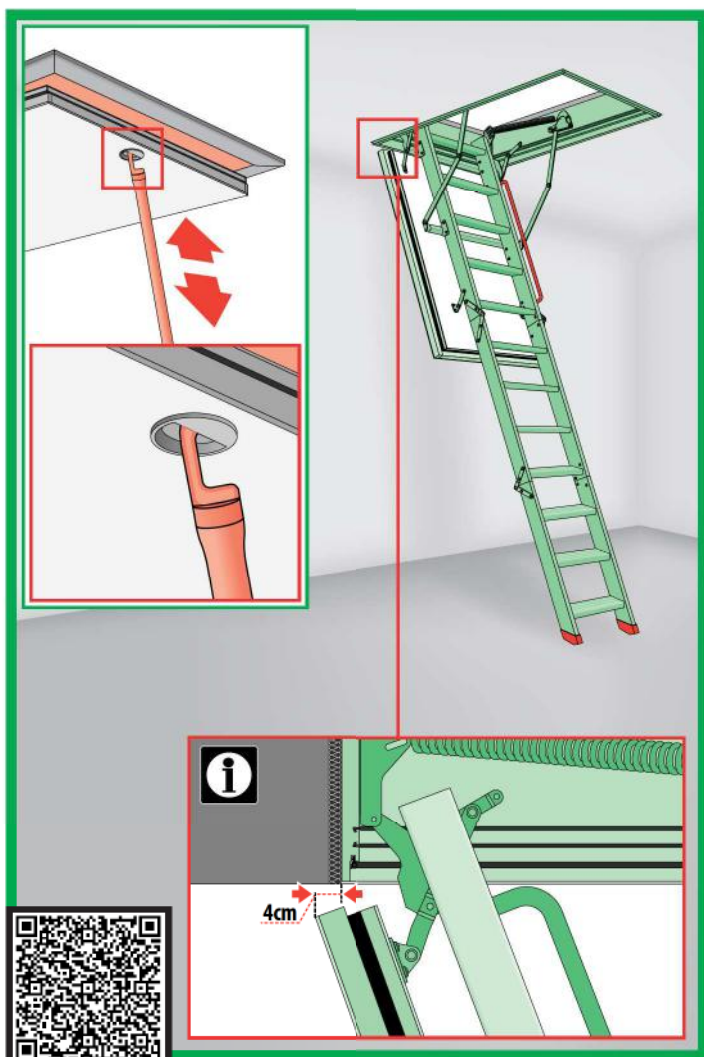

E1,45

# LWF 45

CZ	PROTIPOŽÁRNÍ PŮDNÍ SCHODY	NL	BRANDWERENDE ZOLDERTRAP
DE	FEUERHEMMENDE BODENTREPPPE	PL	SCHODY STRYCHOWE OGNIODPORNE
ES	ESCALERA ESCAMOTEABLE IGNÍFUGA	PT	ESCALADA DE SOTA0-ENCAIXADA
FR	ESCALIER ESCAMOTABLE COUPE-FEU	RO	SCĂRI DE ACCES LA POD REZISTENTE LA FOC
GB	FIRE-RESISTANT LOFT LADDER	RU	ЧЕРДАЧНАЯ ЛЕСТНИЦА С ОГНЕСТОЙКИМ ЛЮКОМ
HU	TŰZÁLLÓ PADLÁSFELJÁRÓ LÉPCSŐ	SK	STROPNÉ PROTIPOŽIARNE SKLÁPACIE SCHODY
IT	LE SCALE PER LA SOFFITTA	US	FIRE-RESISTANT ATTIC STAIRS



<http://www.fakro.com/download/film-installation-instructions/loft-ladders/>

## READ SAFETY INSTRUCTION BEFORE USING

**WARNING!**  
**ACHTUNG!**  
**U W A G A !**  
**ATTENTION!**  
**CUIDADO!**  
**ПРИМЕЧАНИЕ!**



NC 9CE

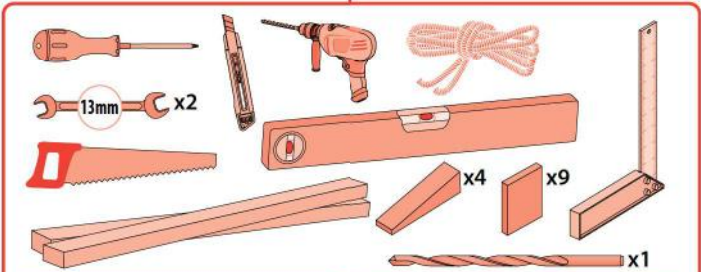

\*

60kg/m<sup>3</sup> A1



\*\*

PROMASEAL

FIRES - JR-008-15-NURE

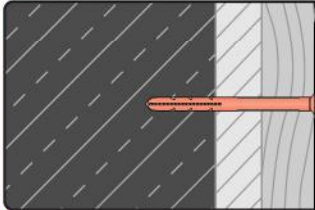

1

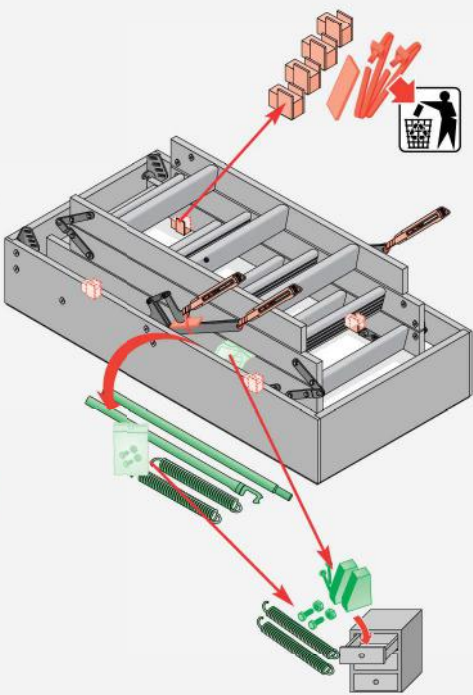
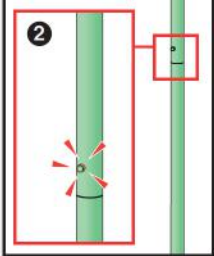
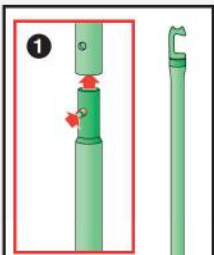

2

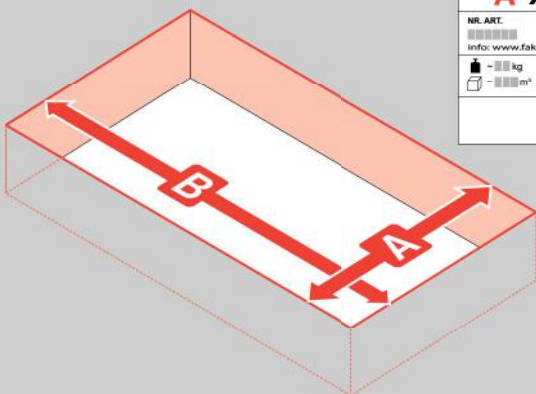

LWF ■■■■ cm

A x B cm

NR. ART.

■■■■■■■■■■  
info: [www.fakro.com](http://www.fakro.com)

■ - ■■■ kg W = ■■■ cm

□ - ■■■ m<sup>2</sup> L = ■■■ cm



3

LXK



NC99L

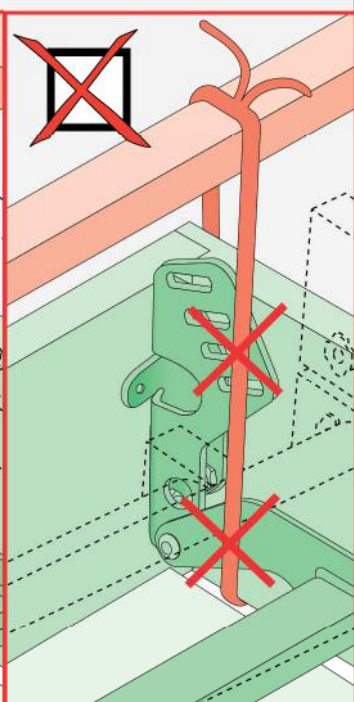
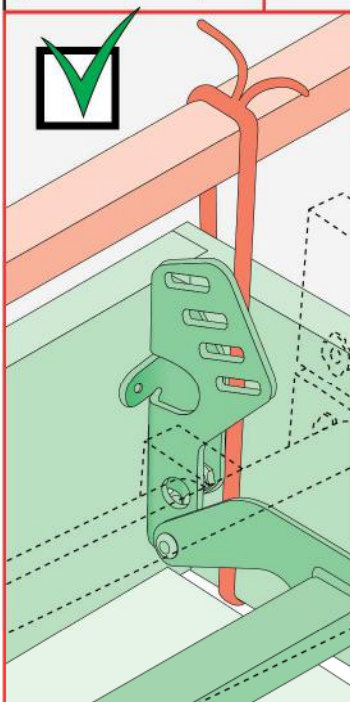
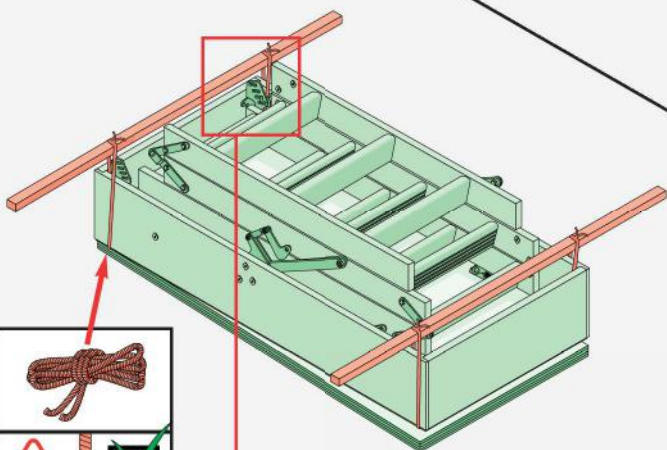
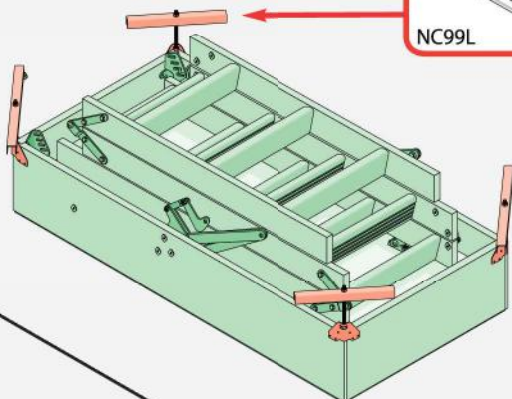

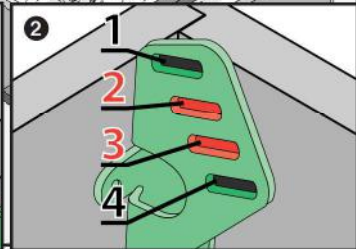
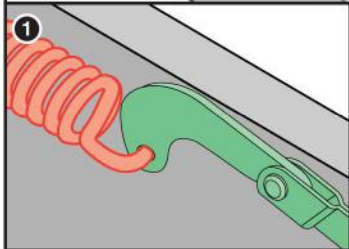
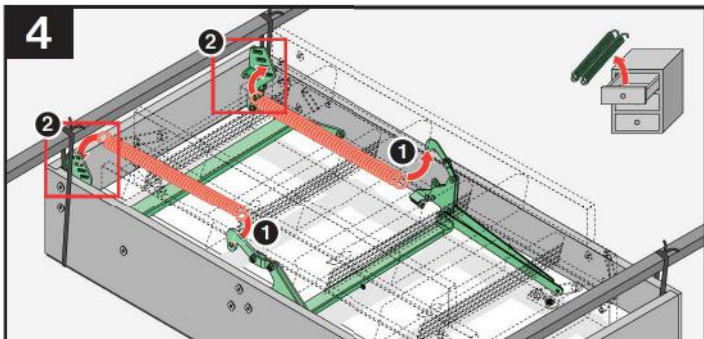

**A x B cm**



70 x 130 cm  
70 x 140 cm  
86 x 130 cm

**A x B cm**



60 x 120 cm  
70 x 120 cm

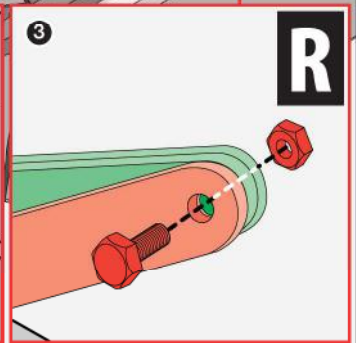
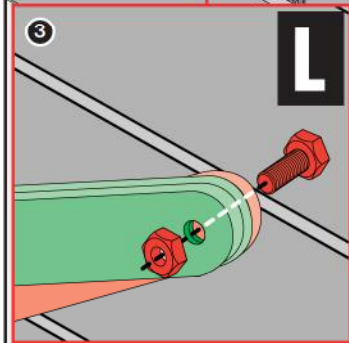
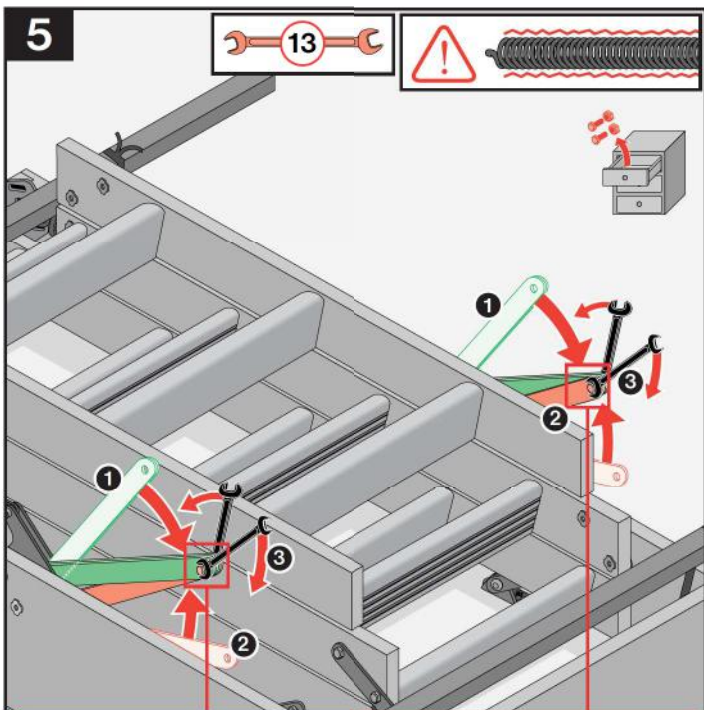
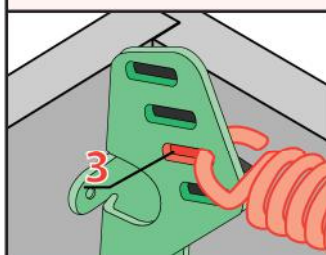
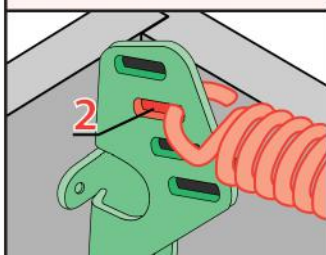

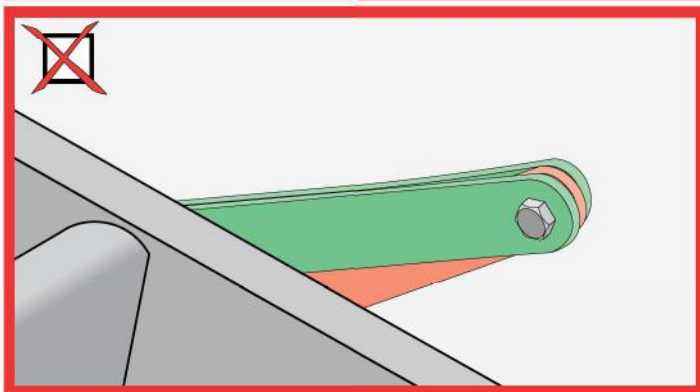
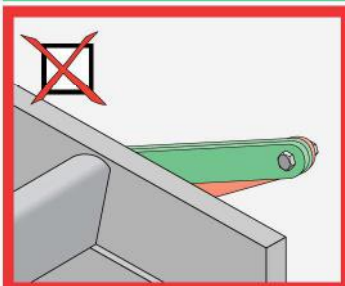
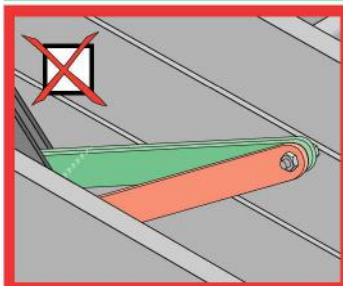
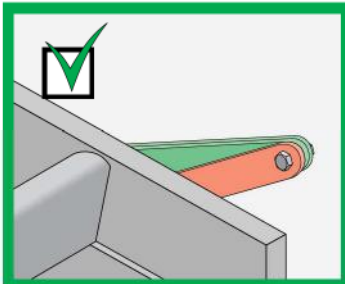
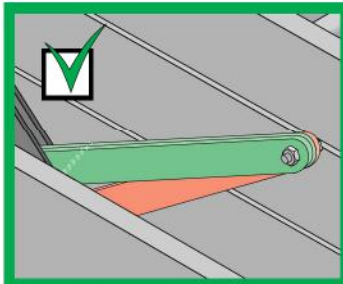
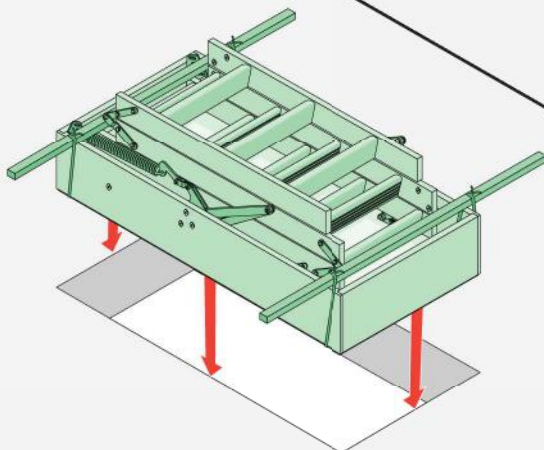
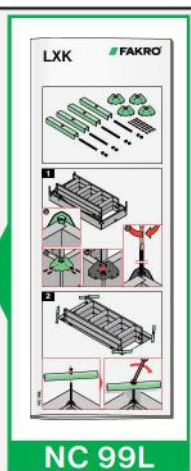
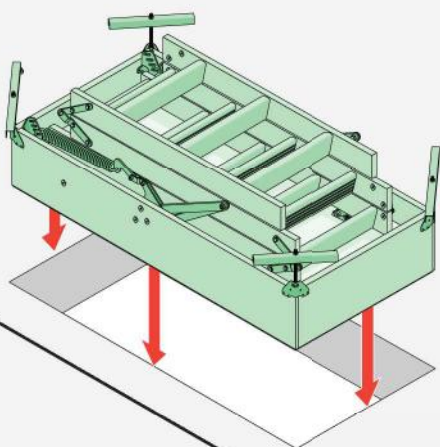
**L****R****6a**

6b

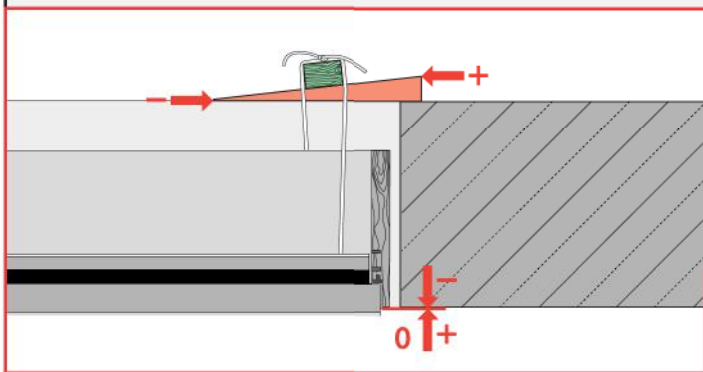
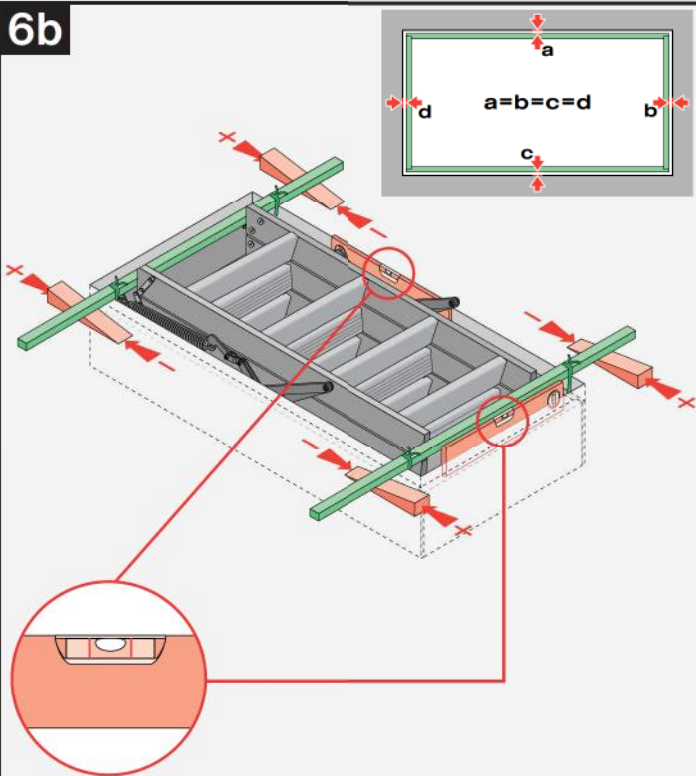

7

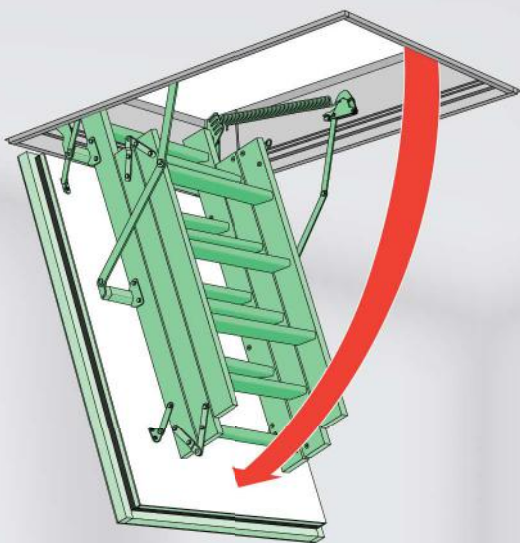

8



8\*

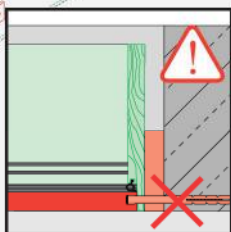
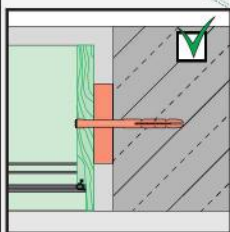
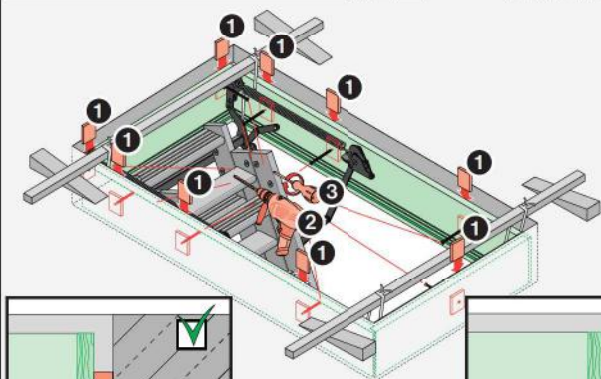
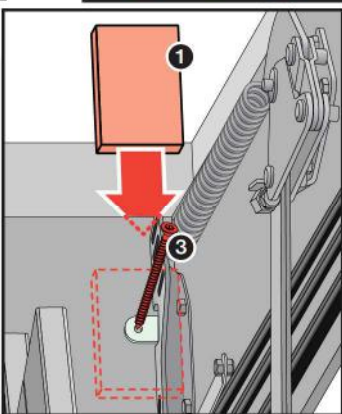
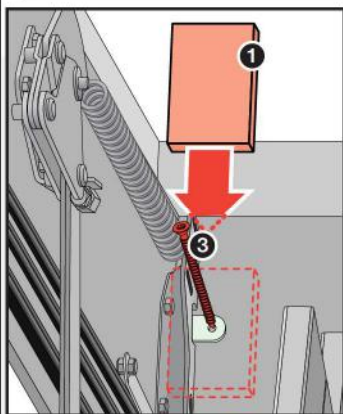

8\*

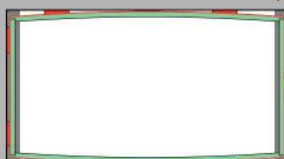

9

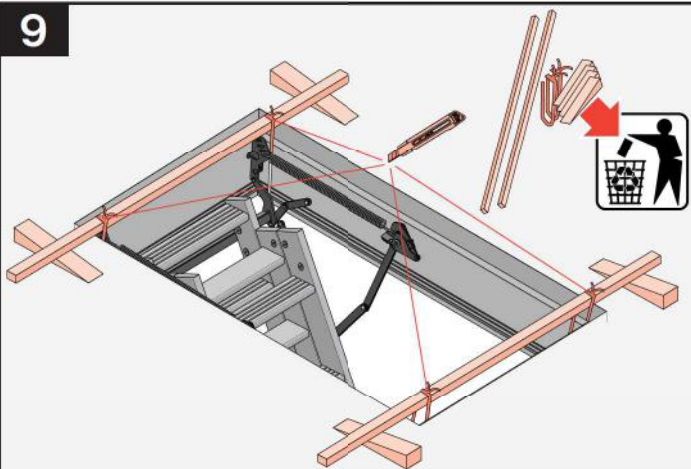

10

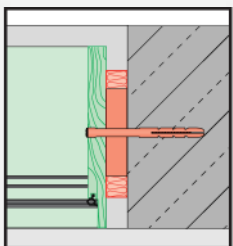
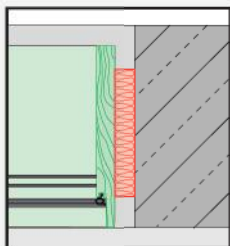
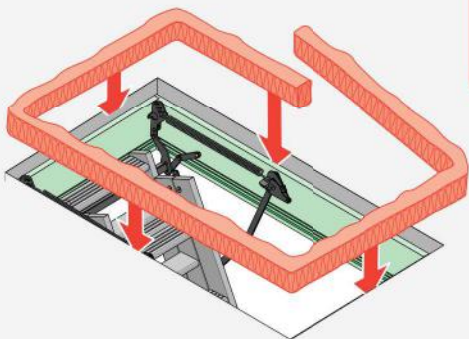
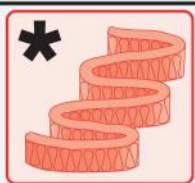

11

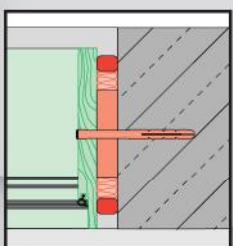
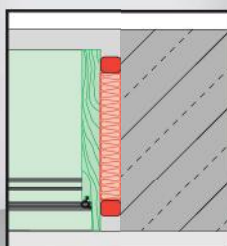
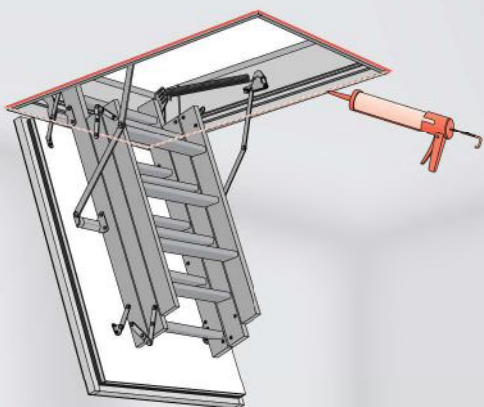
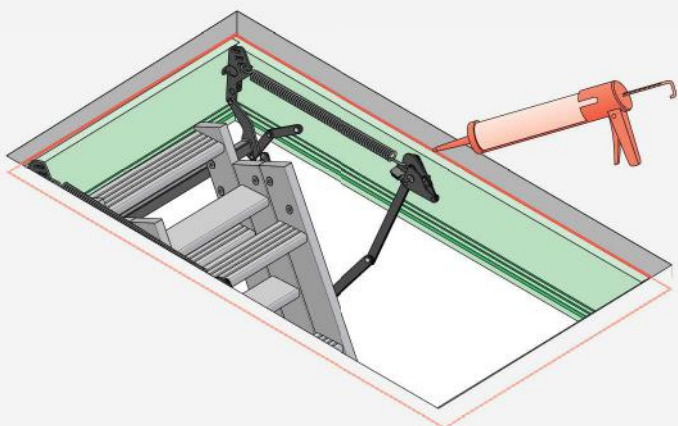



12

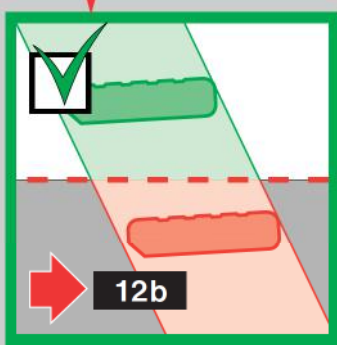
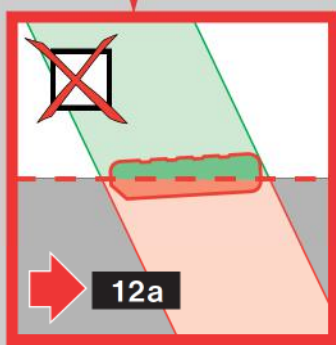
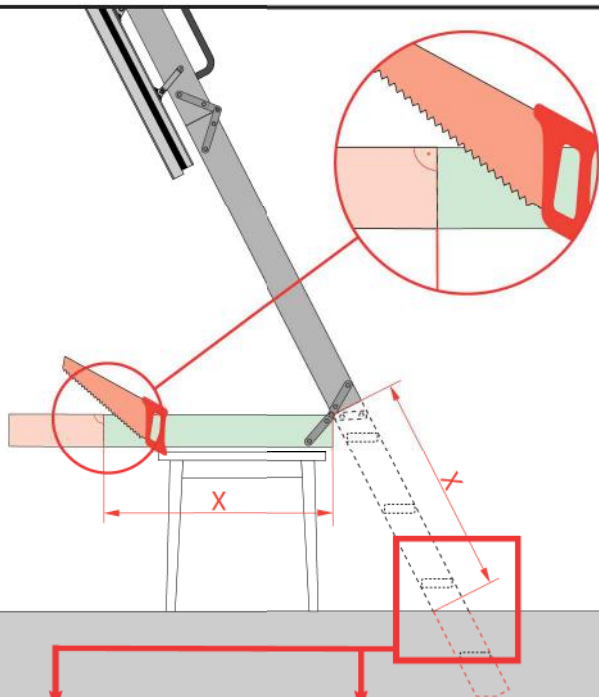

12a

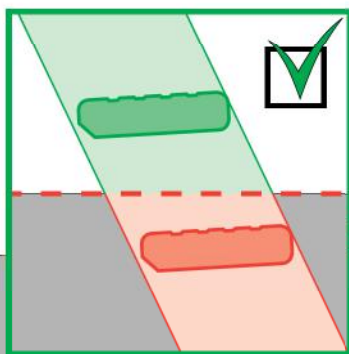
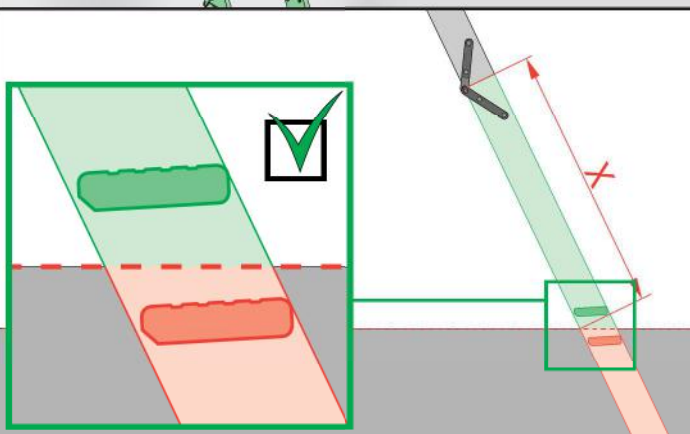
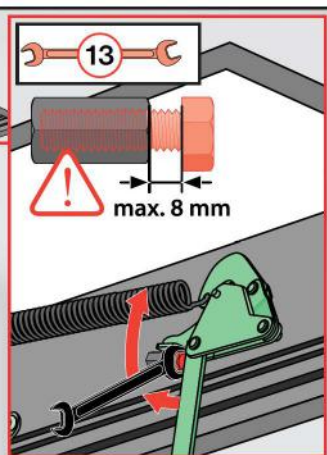

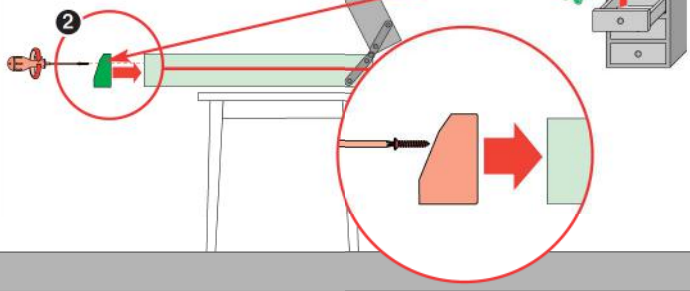
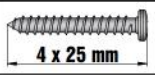
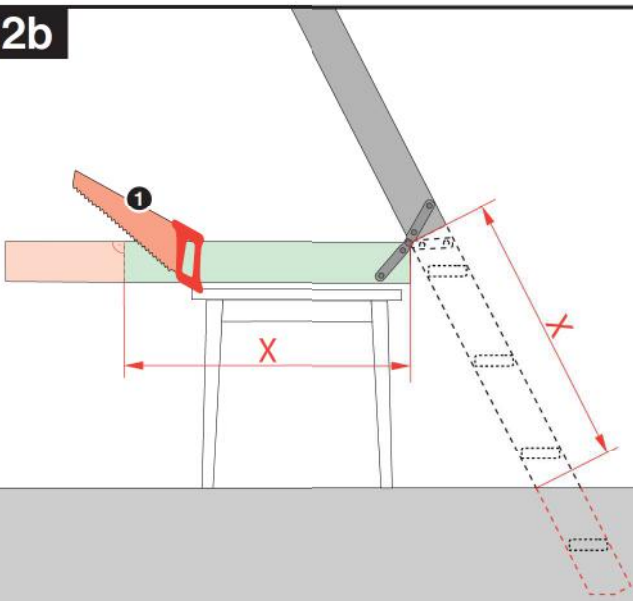
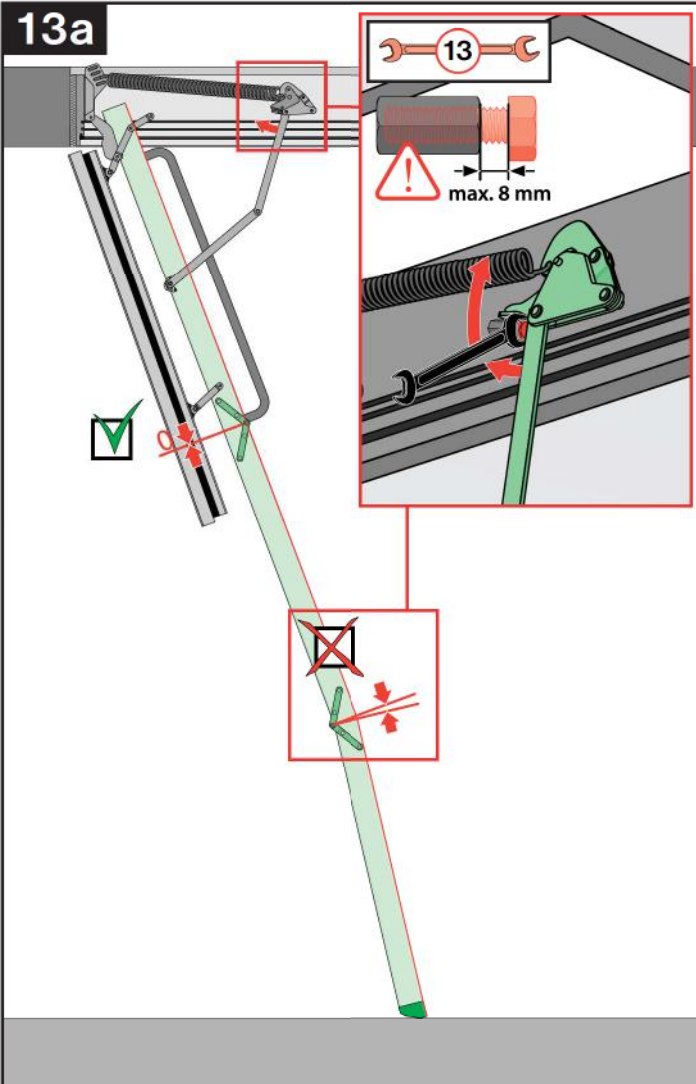
**12b****13a**

13b

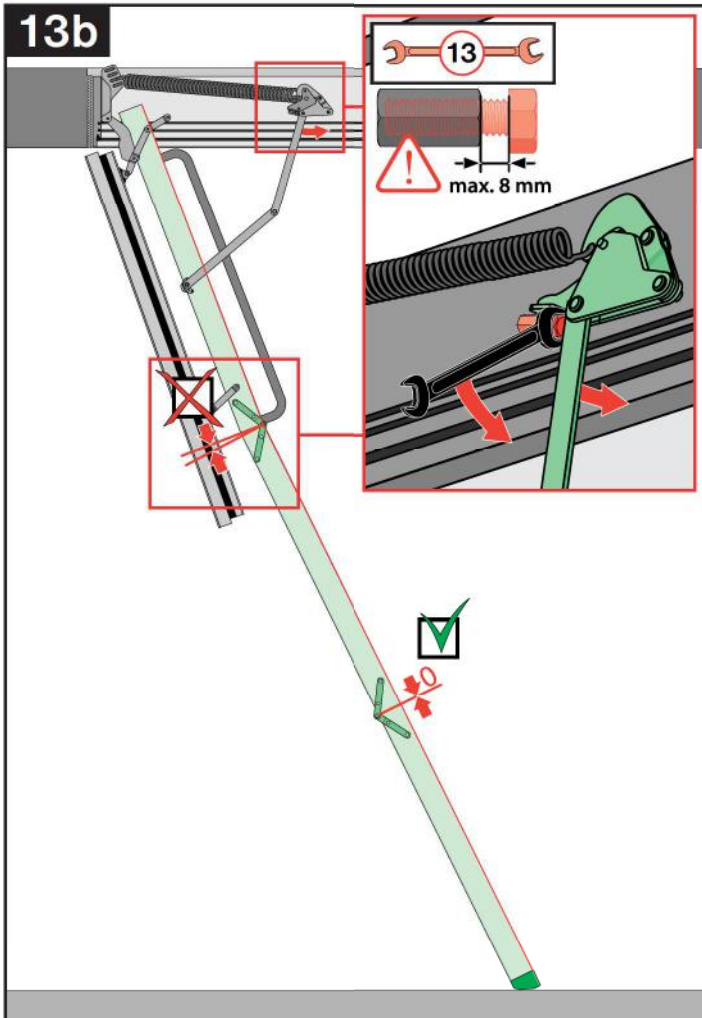

13c

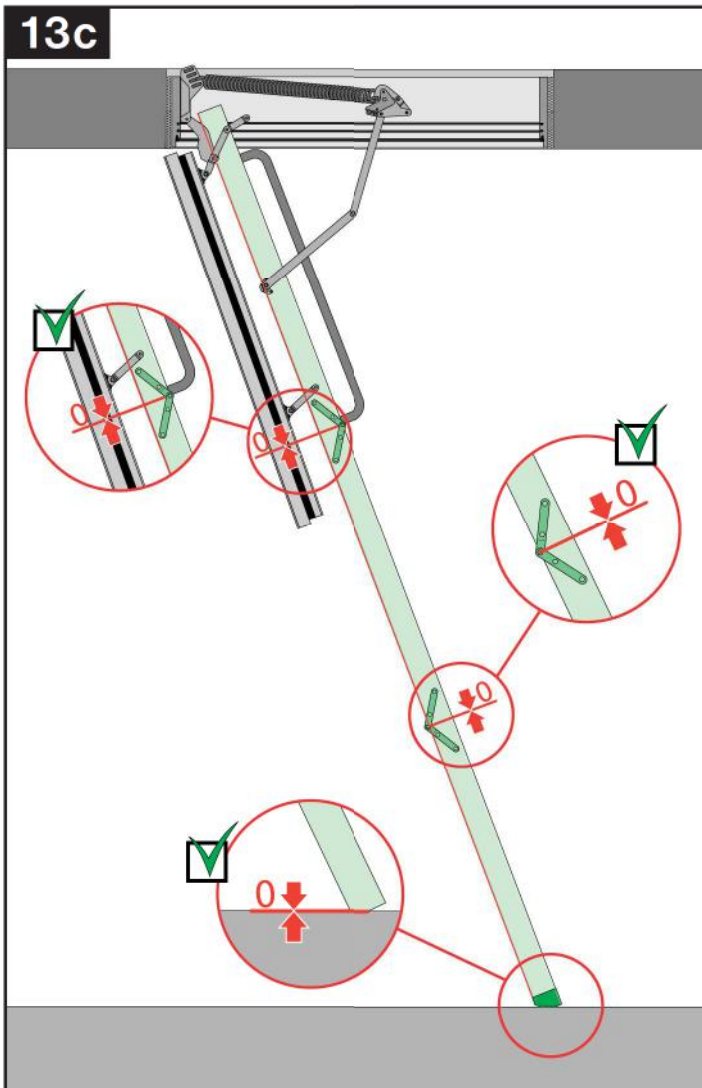

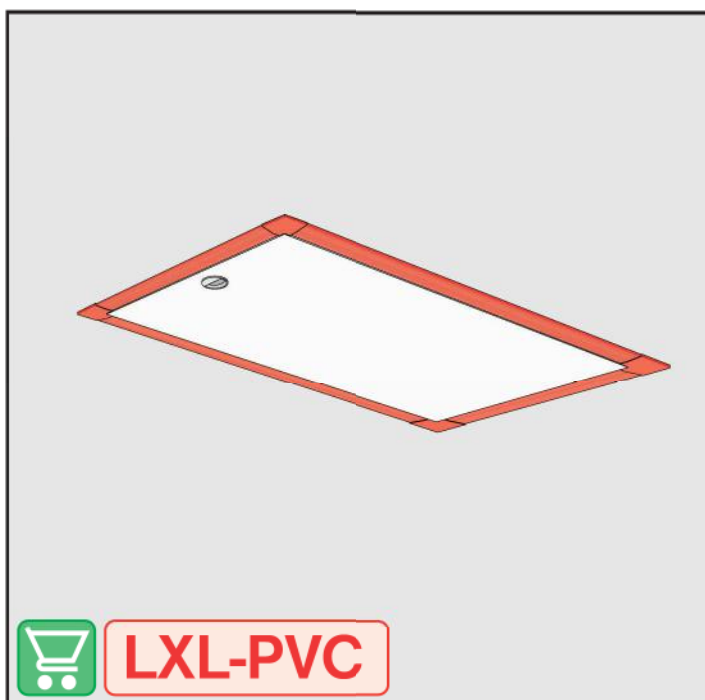
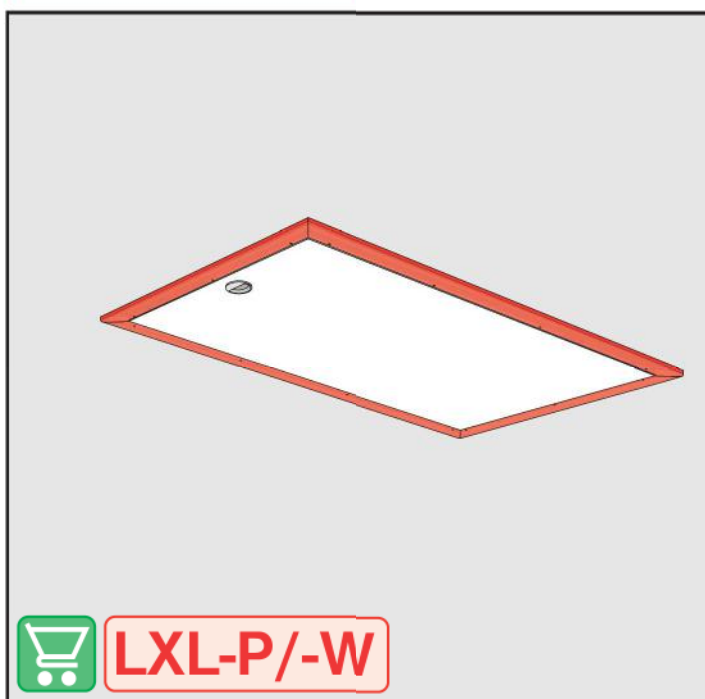
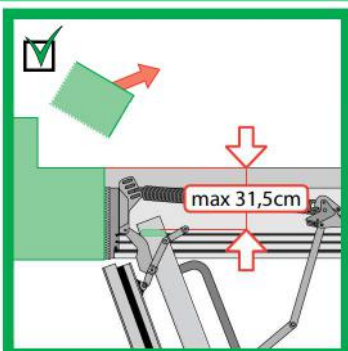
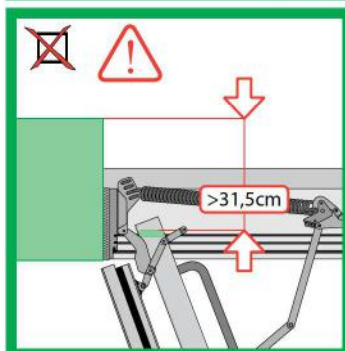
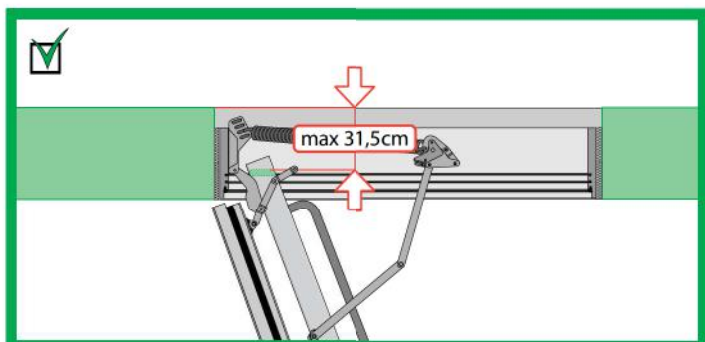

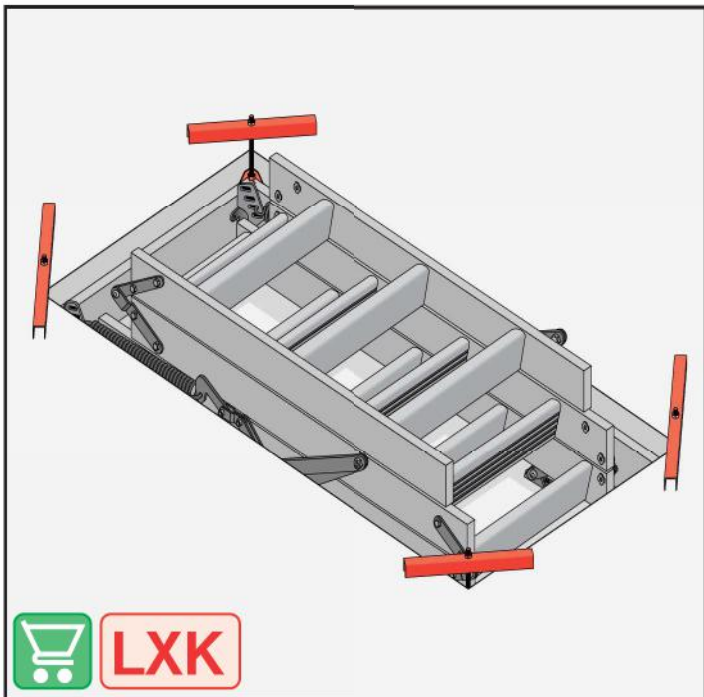





**! WARNING! - ACHTUNG! - UWAGA! - ATTENTION! - CUIDADO! - BИMAMHIE!**



FEUERHEHMENDE BODENTREPPPE  
 ESCALIER ESCAMOTABLE COUPE-FEU  
 FIRE-RESISTANT LOFT LADDER  
 SCHODY SEGMENTOWE OGNIODOPORNE

EN 13501-2

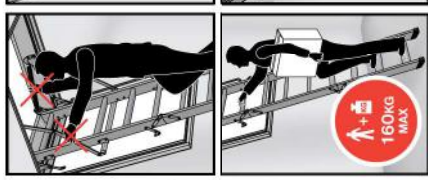
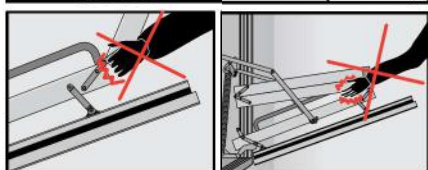
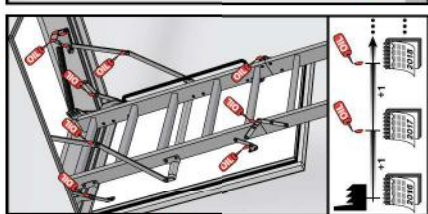
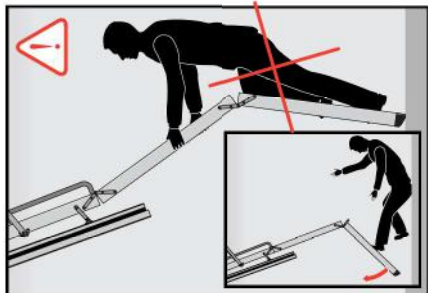
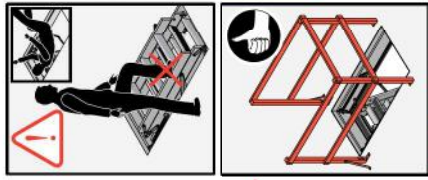
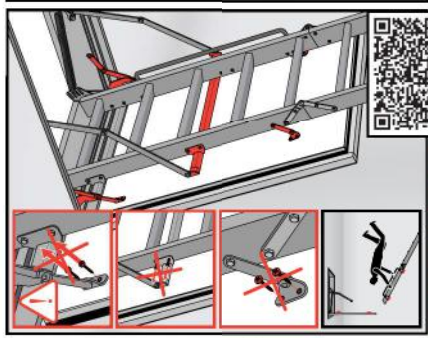

**SAFETY! - SICHERHEIT! - BEZPIECZENSTWO!  
 СЕКУРИТЕ! - SEGURIDAD! - БЕЗОПАСНОСТЬ!**  
<http://www.fakro.com/download/safety-instructions/loft-ladders.php>

EN 14975

**FAKRO**  
 www.fakro.com

Wyrob wprowadzony do obrotu na zasadzie wzajemnego uznawania zgodnie z Art. 5 (punkt 5.3) ustawy o wyrobach budowlanych z dnia 13 czerwca 2013 r. o zmianie ustawy o wyrobach budowlanych oraz ustawy o systemie oceny zgodności (Dz. U. 2013 poz. 898, Art. 5.3).

<b>CZ</b>	Výrobce a Prodávce nenesú žádnou odpovědnost za nedodržení příslušných předpisů zákona, stavebních předpisů a bezpečnostních požadavků plus užívatele výrobku, architekta, montéře nebo majitele objektu.	<b>NL</b>	De fabrikant en verkoper zijn niet aansprakelijk voor gevolgen bij het niet opvolgen van toepasselijke wetten, bouwbesluiten en veiligheidsvoorschriften door de gebruiker van het product, de architect, de installateur of de eigenaar van het gebouw.
<b>DE</b>	Hersteller und Verkäufer übernehmen keine Haftung für Nichtbeachtung entsprechender Rechts- und Bauvorschriften sowie Sicherheitsanforderungen seitens Produktbenutzers, Architekten, Monteurs oder Gebäudebesitzers.	<b>PL</b>	Producent i Sprzedawca nie ponoszą żadnej odpowiedzialności za nieprzebrnięcie stosownych przepisów prawa, przepisów budowlanych i wymogów bezpieczeństwa przez użytkownika produktu, architekta, monterów lub właściciela budynku.
<b>ES</b>	El fabricante y el vendedor no tienen ninguna responsabilidad por el incumplimiento de la ley vigente, normas de construcción y exigencias de seguridad por parte del usuario del producto, arquitecto, instalador o el propietario del edificio.	<b>PT</b>	O fabricante e o vendedor não tem nenhuma responsabilidade pelo o não cumprimento da lei, códigos de construção e as exigências de segurança por parte do usuário do produto, arquiteto, instalador ou proprietário do edifício.
<b>FR</b>	Le fabricant et le revendeur ne prend aucune responsabilité de ne pas respecter les lois applicables, les règlements en vigueur, a legior din domeniul construcțiilor sau a măsurilor de siguranță impuse utilizatorilor produsului, arhitecților, montajorilor sau proprietarilor clădirii.	<b>RO</b>	Nici producătorul, nici distribuitorul nu își vor asuma niciun fel de răspundere pentru nerespectarea legilor în vigoare, a legilor din domeniul construcțiilor sau a măsurilor de siguranță impuse utilizatorilor produsului, arhitecților, montajorilor sau proprietarilor clădirii.
<b>GB</b>	Manufacture and Seller shall bear no liability for failure to comply with the applicable laws, building codes and safety requirements by the user of the product, architect, fitter or owner of the building.	<b>RU</b>	В случае несоблюдения архитектором, монтажником или владельцем здания строительных правил и норм безопасности ответственность с производителя и продавца снимается.
<b>HU</b>	A Gyártó és a Forgalmazó nem vállal semmiféle felelősséget a vonatkozó törvényi, építési és biztonsági előírások termékfelhasználó, építész, beszállító vagy építésszállító általi be nem tartásáért.	<b>SK</b>	Výrobca a predávca nenesú žiadnu zodpovednosť za nedodržanie príslušných ustanovení zákona, stavebných predpisov a bezpečnostných požiadaviek užívateľom výrobku, architektom, montážom alebo majiteľom objektu.
<b>IT</b>	Il Produttore e il Rivenditore non potranno essere ritenuti responsabili per il mancato rispetto, da parte dell'utente del prodotto, del progettista, dell'installatore o del proprietario dell'edificio, delle leggi vigenti, nonché dei regolamenti edilizi e di quelli relativi alla sicurezza.		